

Sheet (2)

- 1- Two chambers with the same fluid at their base are separated by a piston whose weight is 25 N, as shown. Calculate the gauge and absolute pressures A and B.

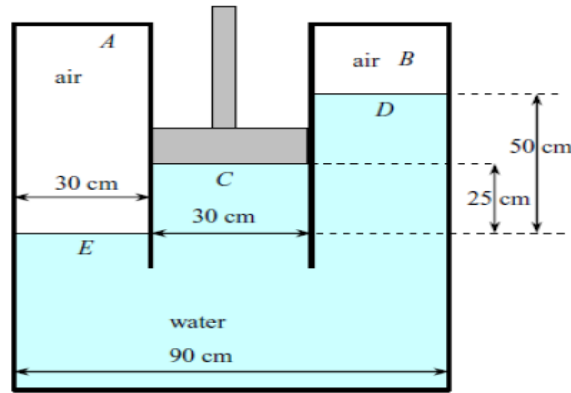

- 2- A manometer is used to measure the pressure in a tank. The fluid used has a specific gravity of 0.85, and the manometer column height is 55 cm, as shown in Figure. If the local atmospheric pressure is 96 kPa, determine the absolute pressure within the tank.

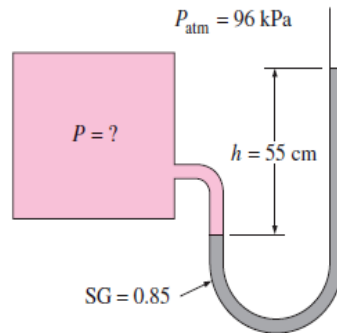

- 3- The water in a tank is pressurized by air, and the pressure is measured by a multi fluid manometer as shown in Figure. The tank is located on a mountain at an altitude of 1400 m where the atmospheric pressure is 85.6 kPa. Determine the air pressure in the tank if $h_1 = 0.1$ m, $h_2 = 0.2$ m, and $h_3 = 0.35$ m. Take the densities of water, oil, and mercury to be 1000 kg/m^3 , 850 kg/m^3 , and $13,600 \text{ kg/m}^3$, respectively.

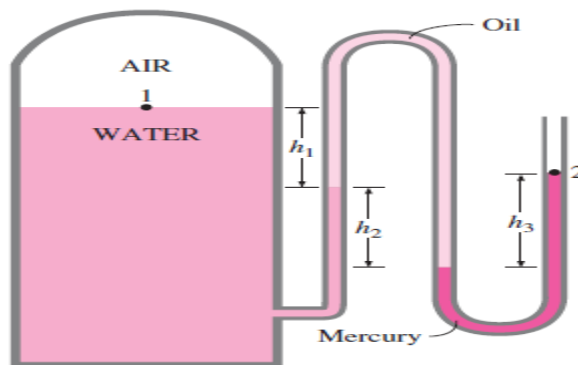

- 4- Find the mass of the oil (S.G.=0.81) poured required to produce a level rise of 4 cm in the left leg above the given level.

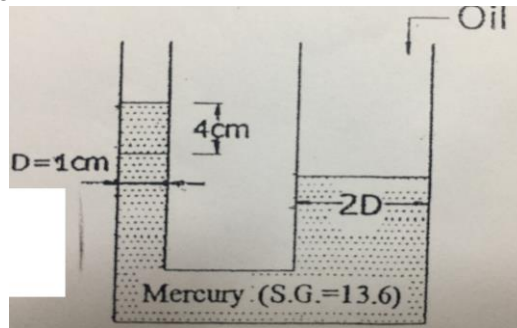

- 5- A barometer is used to determine the height of building. If the barometric readings at the top and bottom of the building are 730mmHG and 750 mmHg respectively, determine the height. Use air density of 12 kg/m^3 .
- 6- Two U-tube manometer, one upright and other is inverted are connecting across a water line and an oil line as shown in figure. What will h_2 be, given that $h_1 = 50\text{ mm}$.

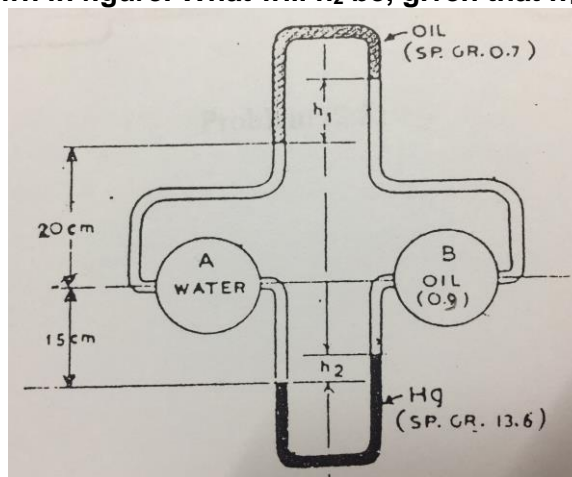

- 7- For the shown diagram, the two open ended limbs subjected to atmospheric pressure with inside diameter 7mm, while the two open ended diameter A, B are 44mm. find the pressure difference between A and B due to increased pressure applied to side B if the separate surface moves 100mm, given that the sp. gravity of oil is 0.83.

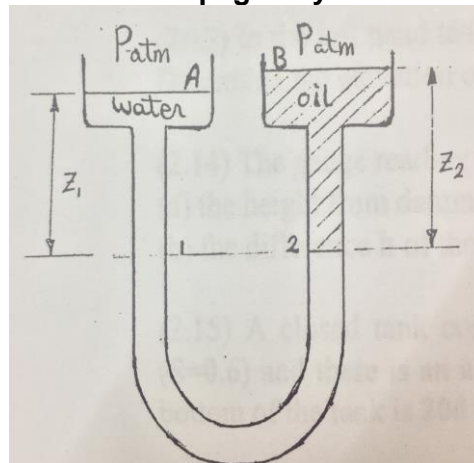

8- For the shown manometer, determine the absolute pressure at the center of pipe A.

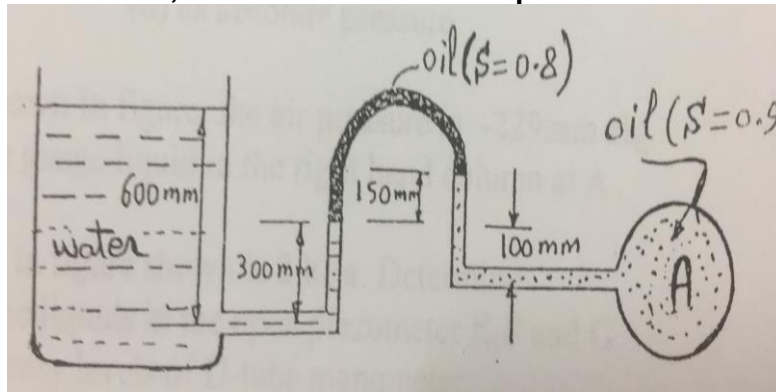

9- For the shown manometer, determine the pressure difference between A and B.

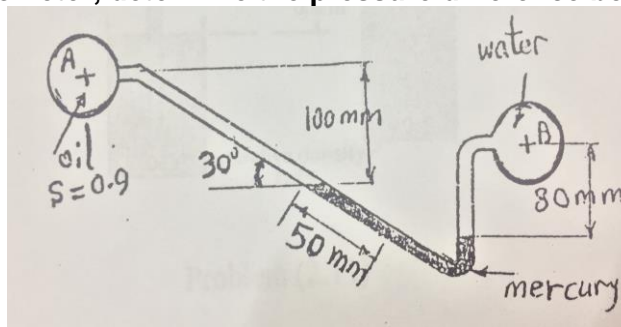

10- The container shown in figure holds water and air. What is the pressure at A, B, C and D in Pascal?

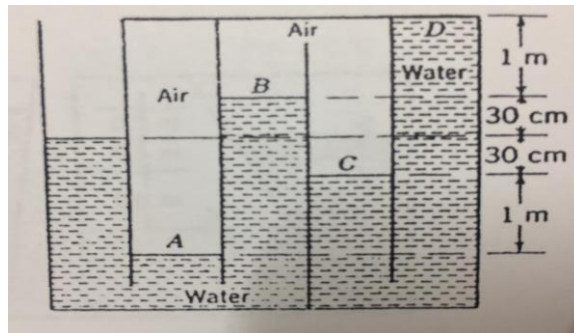

11- The hydraulic press, shown in figure, is used to carry a load of 2 tons. Find the force required to keep the press balanced.

